

Instruction

GIRRO SIM PEDALS PRO XR

Spis treści

1. [Calibration](#)
2. [Throttle and clutch adjustment](#)
3. [Brake adjustment](#)
4. [Possible brake configurations](#)
5. [Protection and care](#)
6. [Mounting schematics](#)
7. [Connection of the clutch and brake](#)
8. [Mounting the damper on the brake](#)

➤ Calibration

1. Download DiView:

http://www.leobodnar.com/shop/index.php?main_page=page&id=12

2. Turn on DiView and click Edit->Settings, Mark only Load Cell Interface LC-USB like on the screenshot

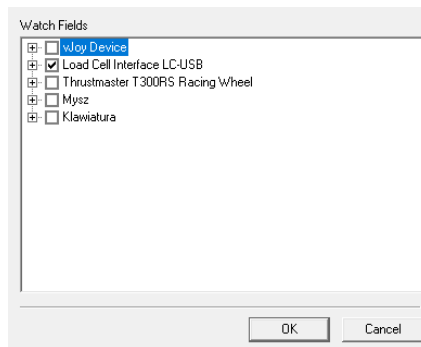

3. Then right-click on each axis and select VIEW RAW DATA. You should see a red indicator and numbers, as shown in the picture.

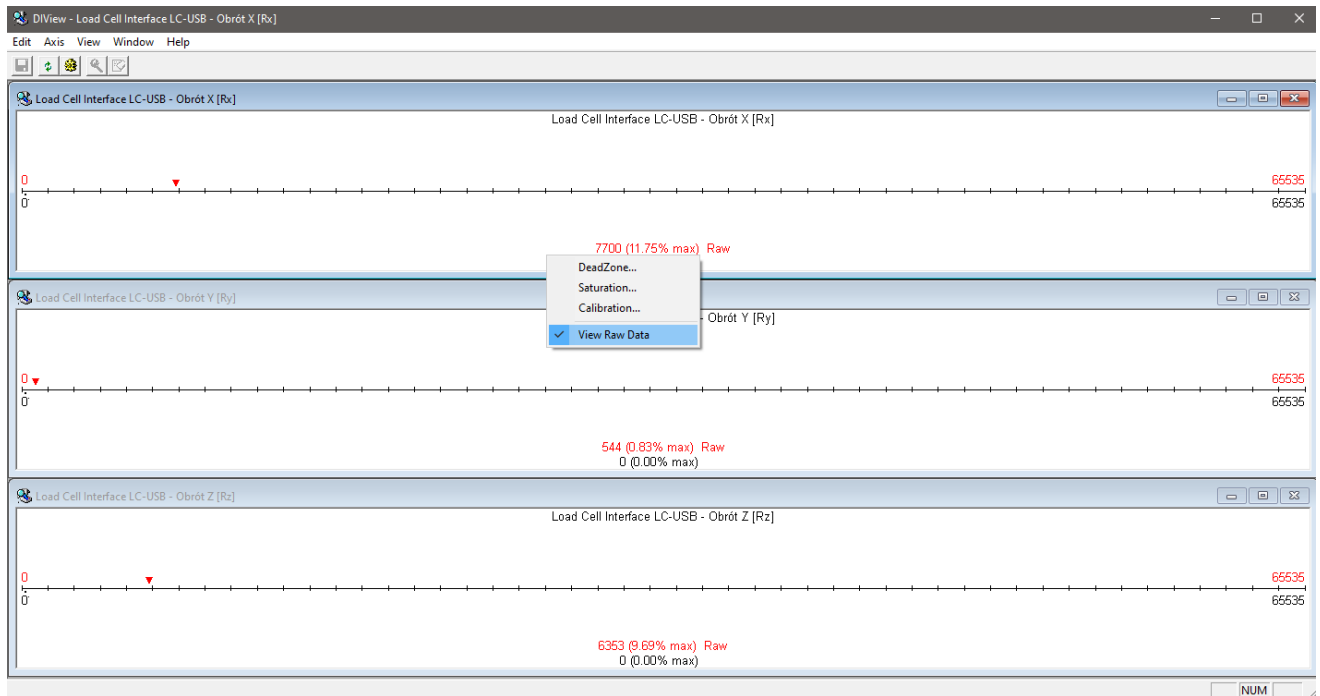

4. Then right-click on any axis again and click CALIBRATION. You will see a window shown below.



5. In the calibration, we consider only the red numbers the X-axis pedal at rest is 7700. Add about (300 to 500) to this number and enter in the MIN box

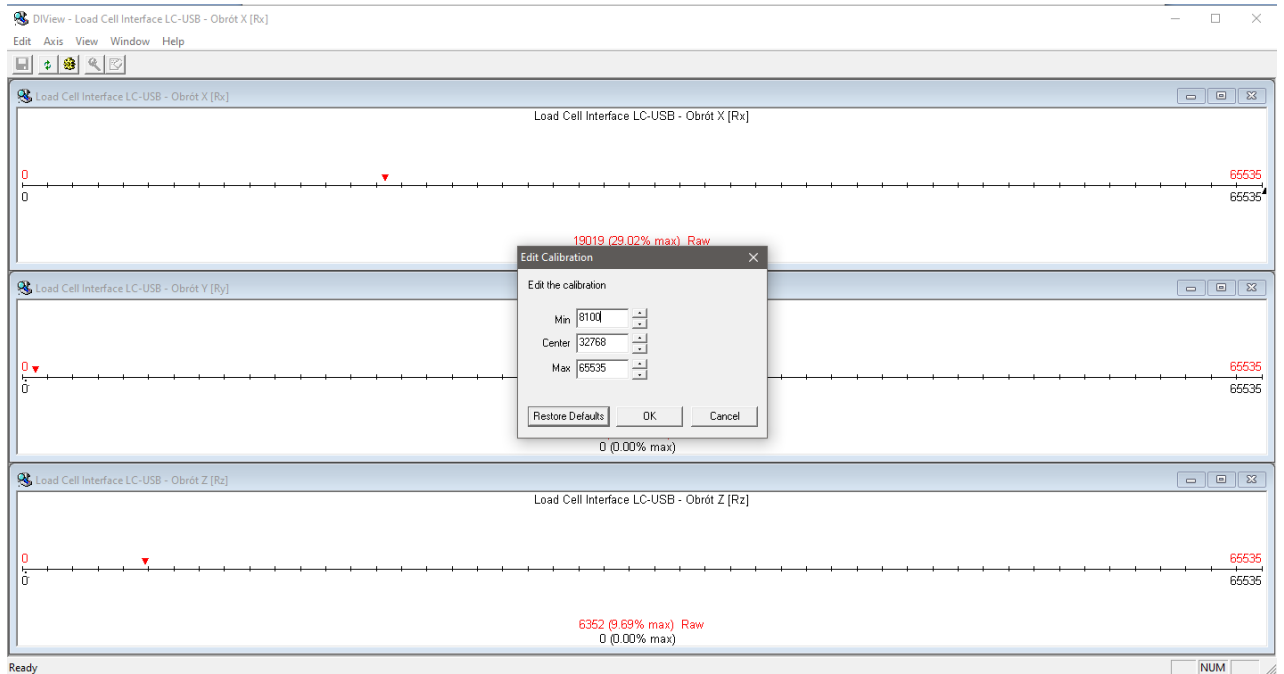

- Press the pedal to the end of the range and subtract 300 to 500 from the red number (19019 on the photo). This time subtract from 300 to 500 and enter the number in the MAX column.

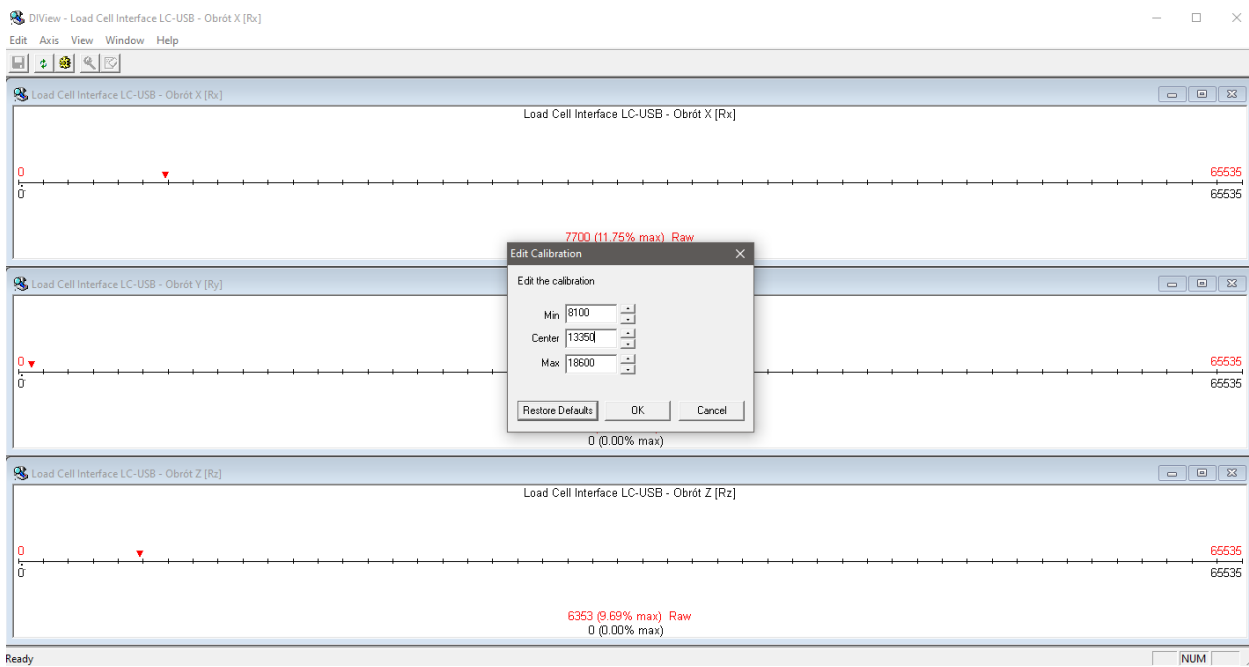

- Center is calculated by adding MAX to MIN and dividing by two. In this case, $(18600+8100)/2=13350$.
- Then repeat the steps from pt. 4 to 7 for the next pedals.

*in IRACING you have to recalibrate the pedals in the game, if you want to have the pedals set more precisely as in DIVIEW the most convenient way is to change the values in the file (joyCalib) in documents -> iRacing after calibration in the game.

*if you have individual settings for each car then you have to change the files (joyCalib) in documents -> iRacing-> setups-> the respective car e.g. subaruwxsti

*CalibCenter stands for the minimum value, i.e. the Min field in DiView

```
joyCalib — Notatnik
Plik Edycja Format Widok Pomoc
- DeviceName: 'Load Cell Interface LC-USB'
- InstanceGUID: '{51BE44C0-9BB2-11E8-800A-444553540000}'
AxisList:
- Axis: 0
  AxisName: 'Obrót Z'
  CalibMin: 500
  CalibCenter: 6989
  CalibMax: 17832
- Axis: 1
  AxisName: 'Obrót Y'
  CalibMin: 617
  CalibCenter: 3700
  CalibMax: 19000
- Axis: 2
  AxisName: 'Obrót X'
  CalibMin: 7477
  CalibCenter: 8300
  CalibMax: 18600
```

➤ Adjustments of gas and clutch

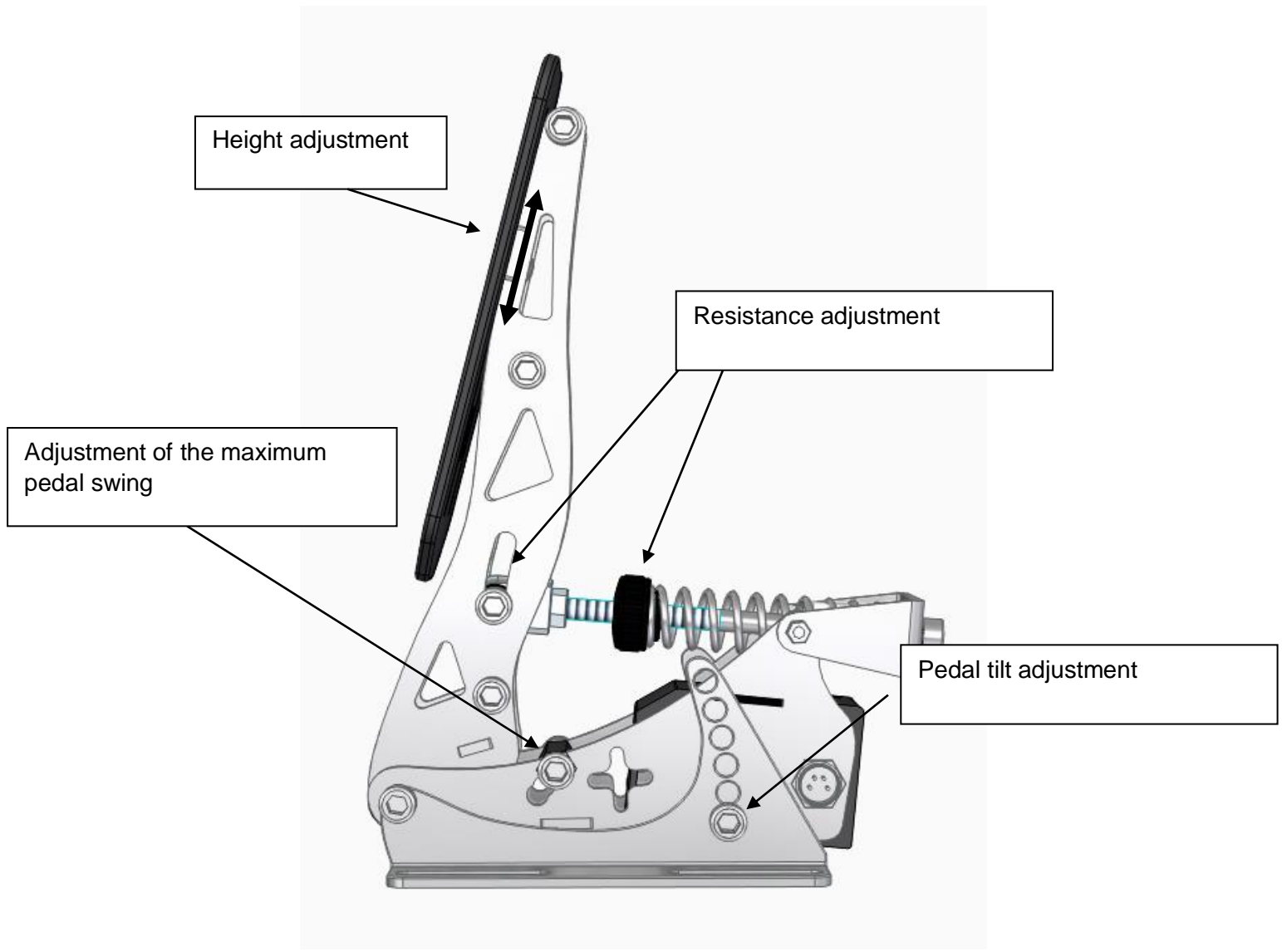

➤ Brake adjustment

When adjusting the inclination of the pedal, unscrew the screw on one side change the position and then do exactly the same on the other side.

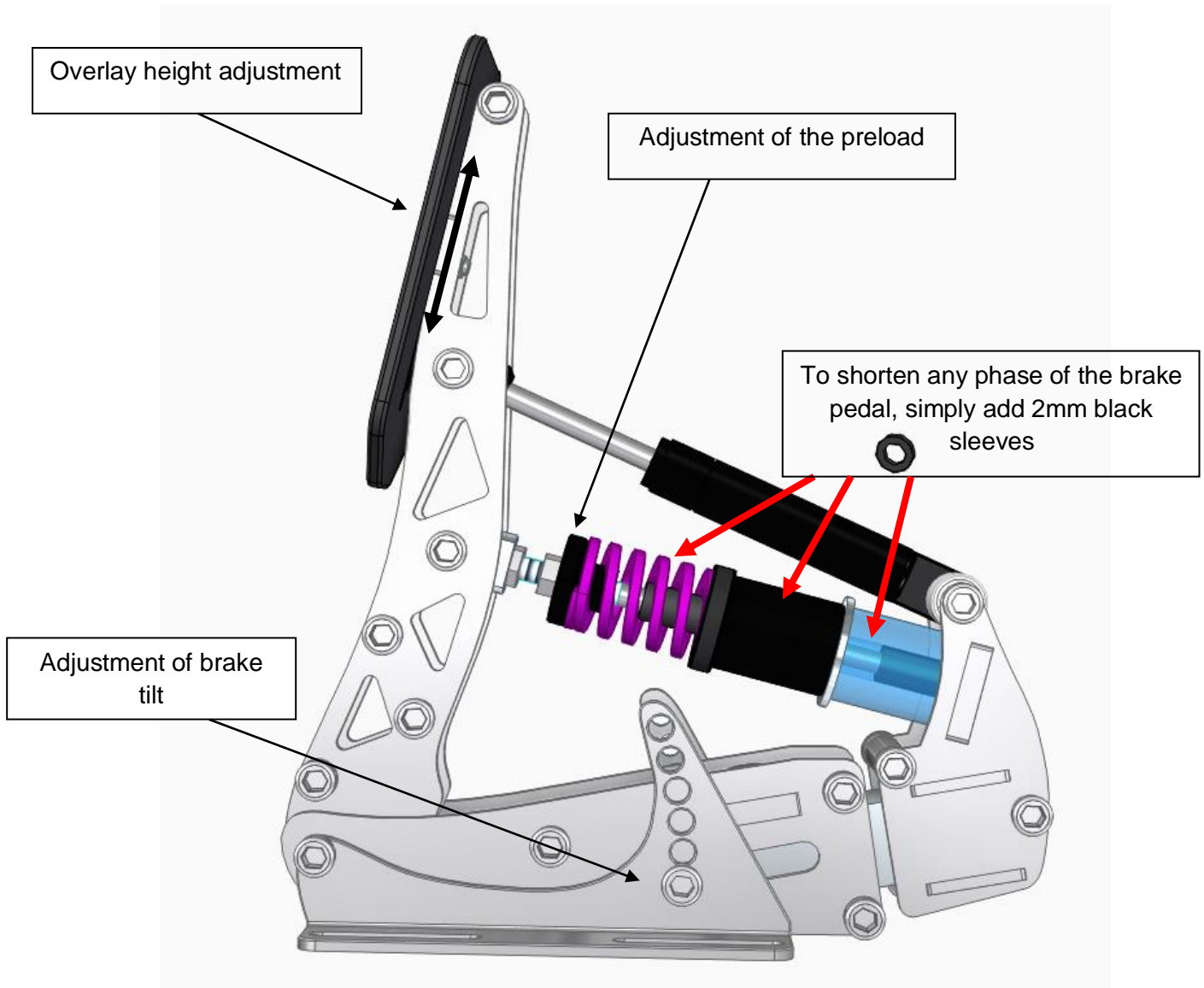

➤ Possible brake pedal configurations

I present here some possible configurations, but you can experiment for yourself. To properly determine what works best for you, it is best to try several configurations. You have to remember to leave the grey bushing under the bolt and you have to insert the black bushing first before inserting each elastomer, this prevents excessive flexing of the elastomers.

When changing the settings, tighten the screw until it stops and loosen it $\frac{1}{4}$ turn to the left. Then tighten the nuts.

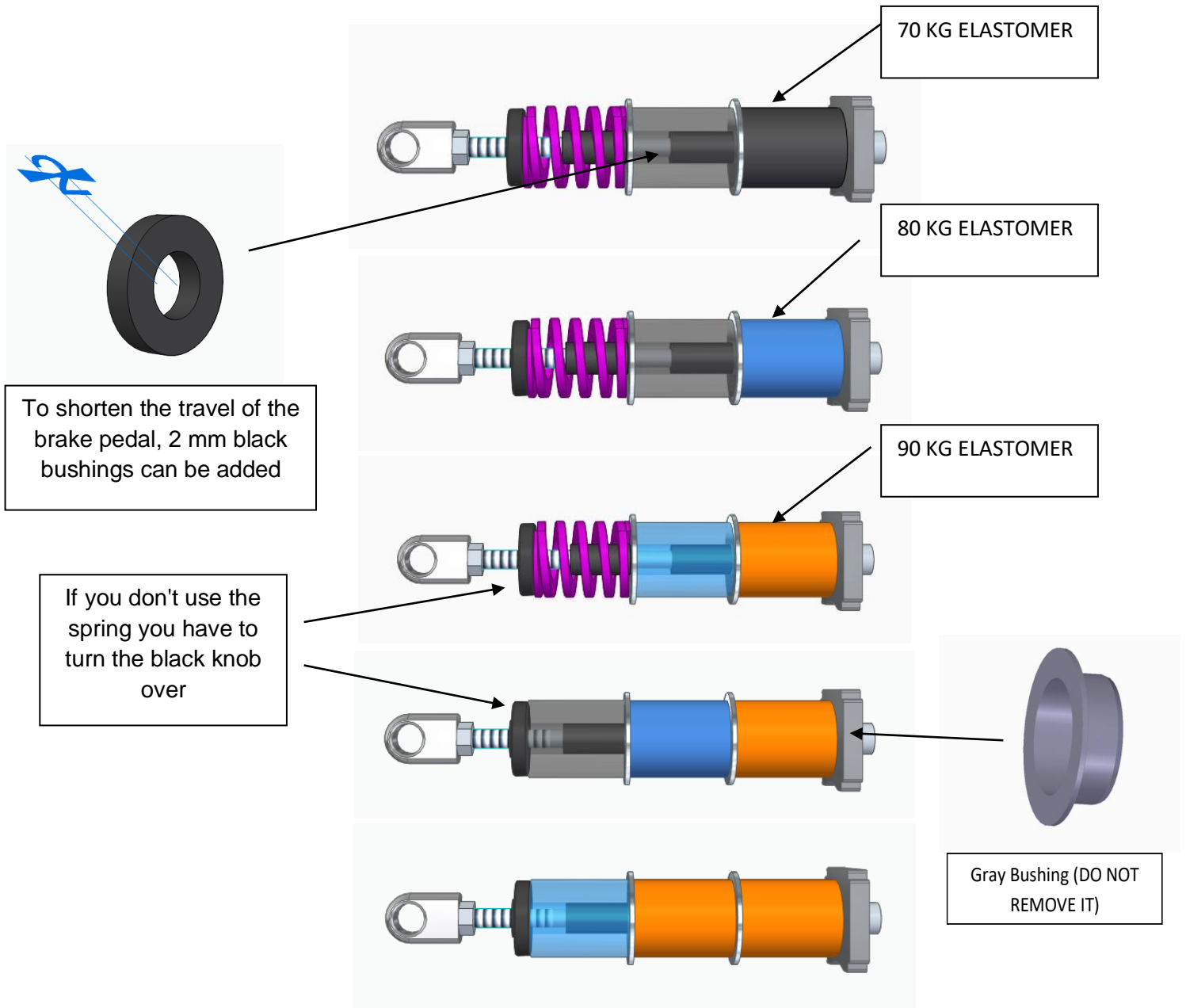

➤ Protection and care

Some areas should be sprayed from time to time with preferably dry PTFE grease. This will keep the pedals working for a long time and eliminate squeaks. When changing elastomer springs, it is also worth spraying into the interior of the springs to ensure adequate slip. Examples of products below in the photos.



Areas prone to friction:

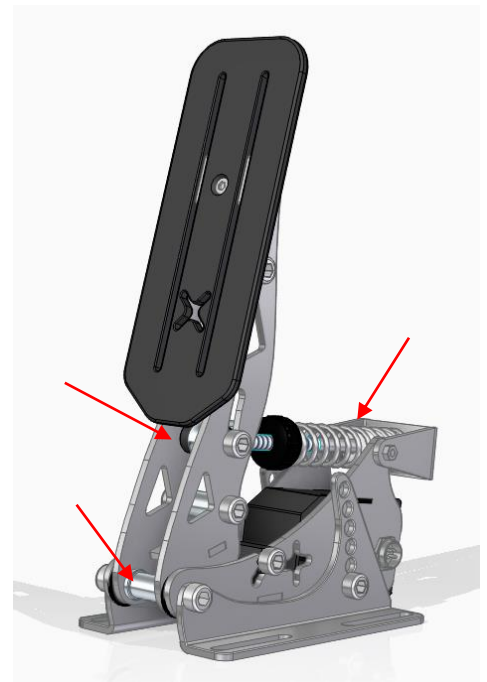
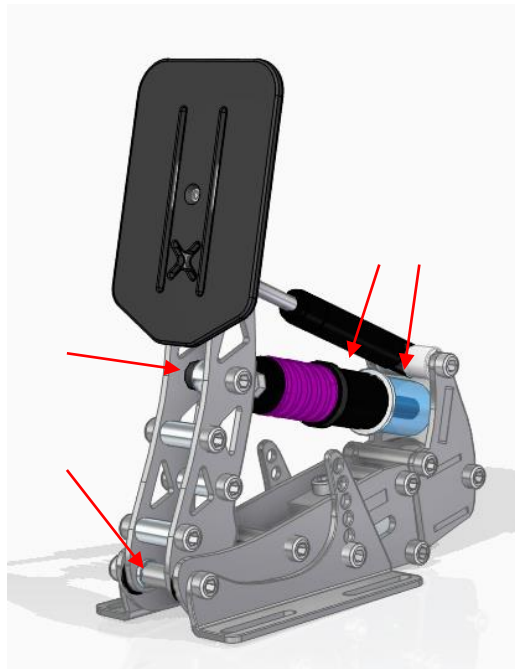
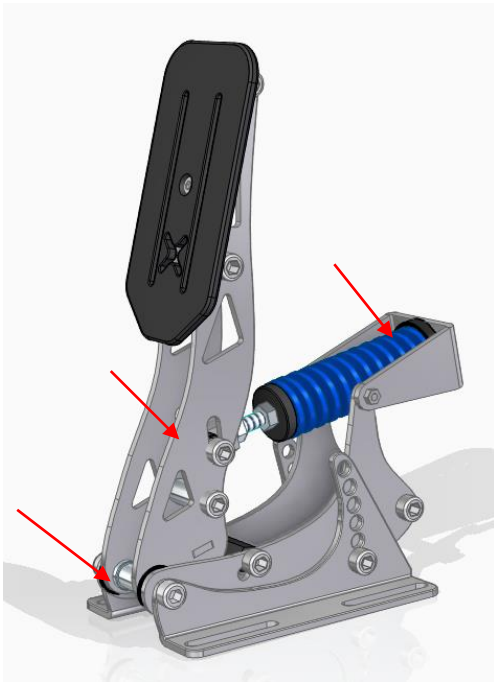

➤ Mounting schematics

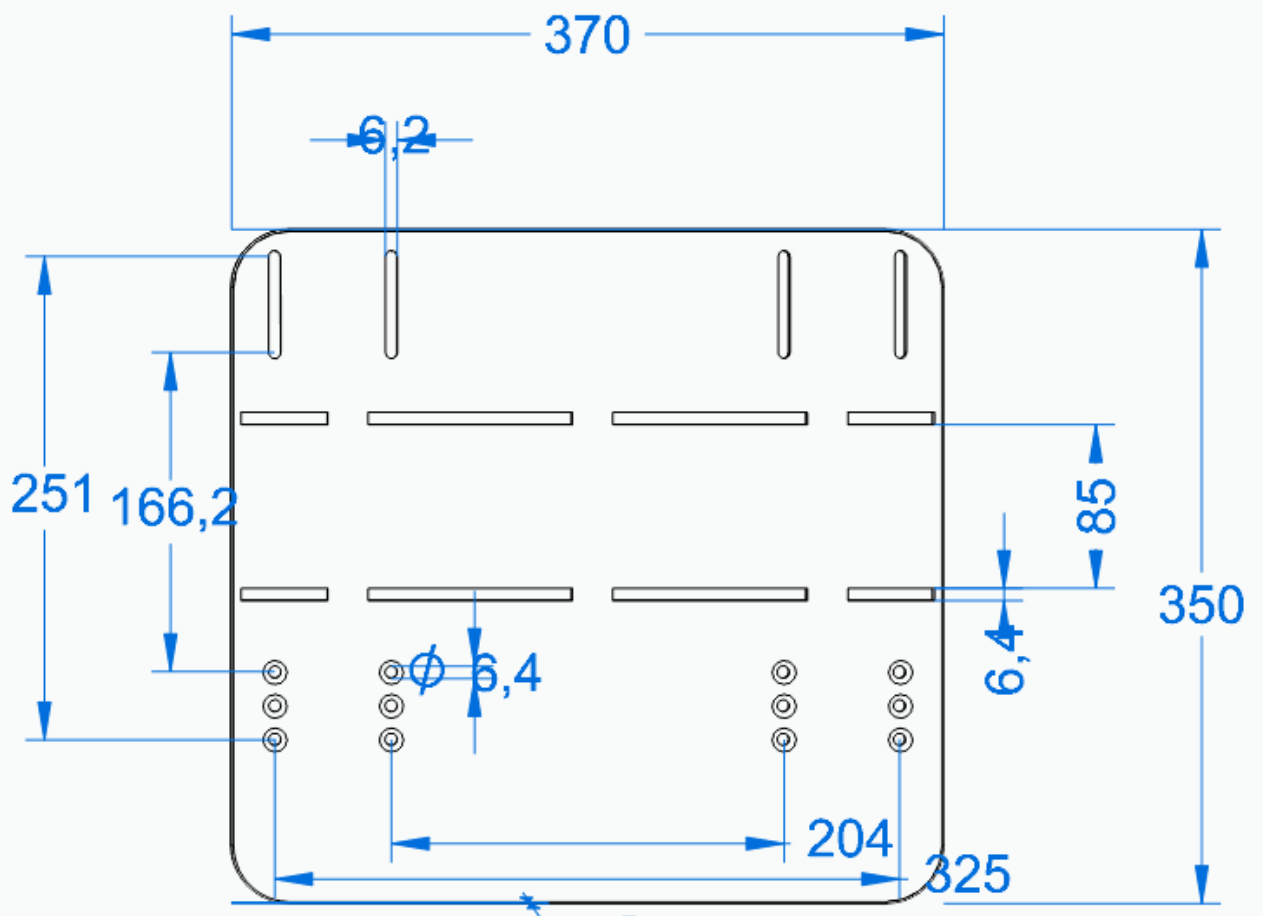
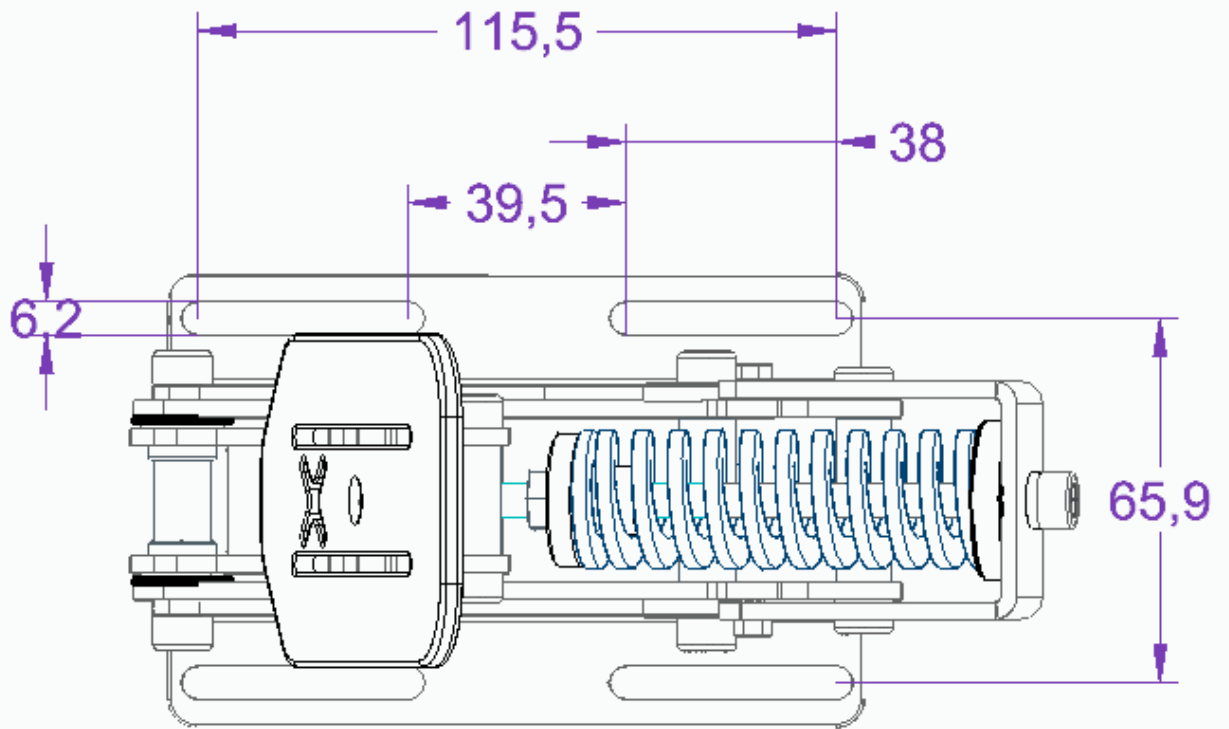

➤ Connection of the clutch and brake

We connect the clutch to the unfastened pedals from the computer.

We insert the brake cable into the four-pin plug (making sure to match the grooves). Then, to secure it, we twist the nut.

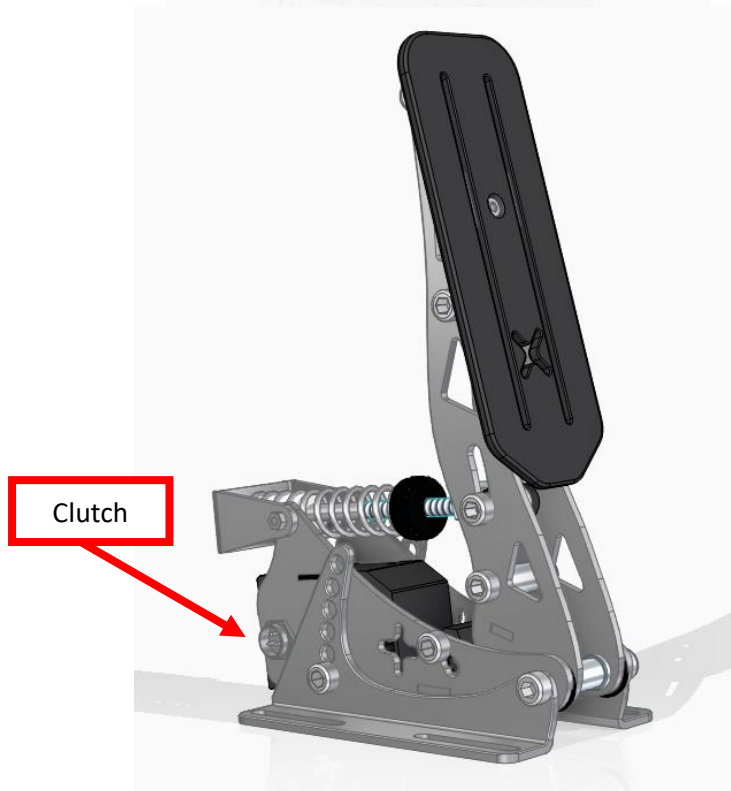
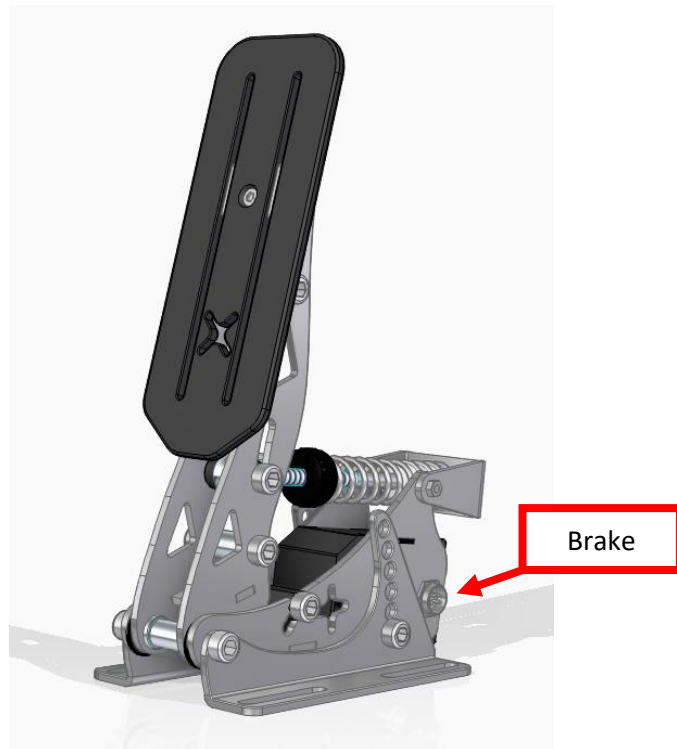

Now you can connect the pedals to the computer.

➤ Mounting the damper on the brake

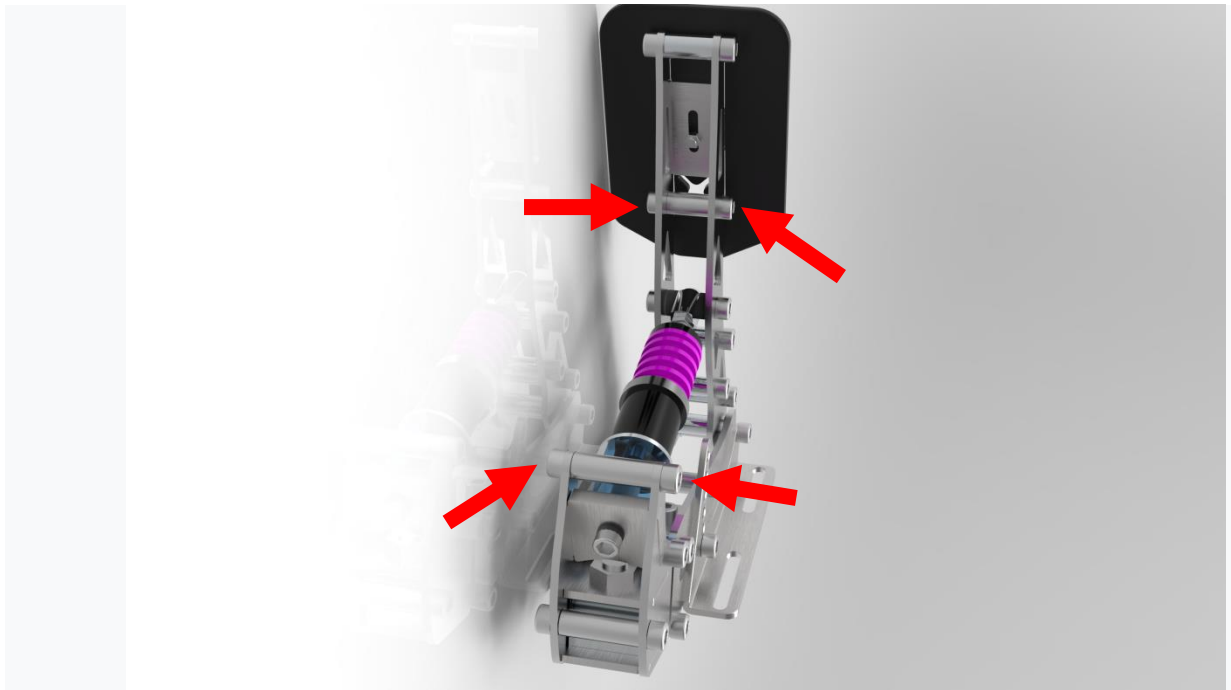

a) Remove all screws marked with red arrows and remove them metal bushings



b) Mount the damper with two screws M6x30 on top and M6x40 below. Assemble the damper in the order of parts as in the picture above.

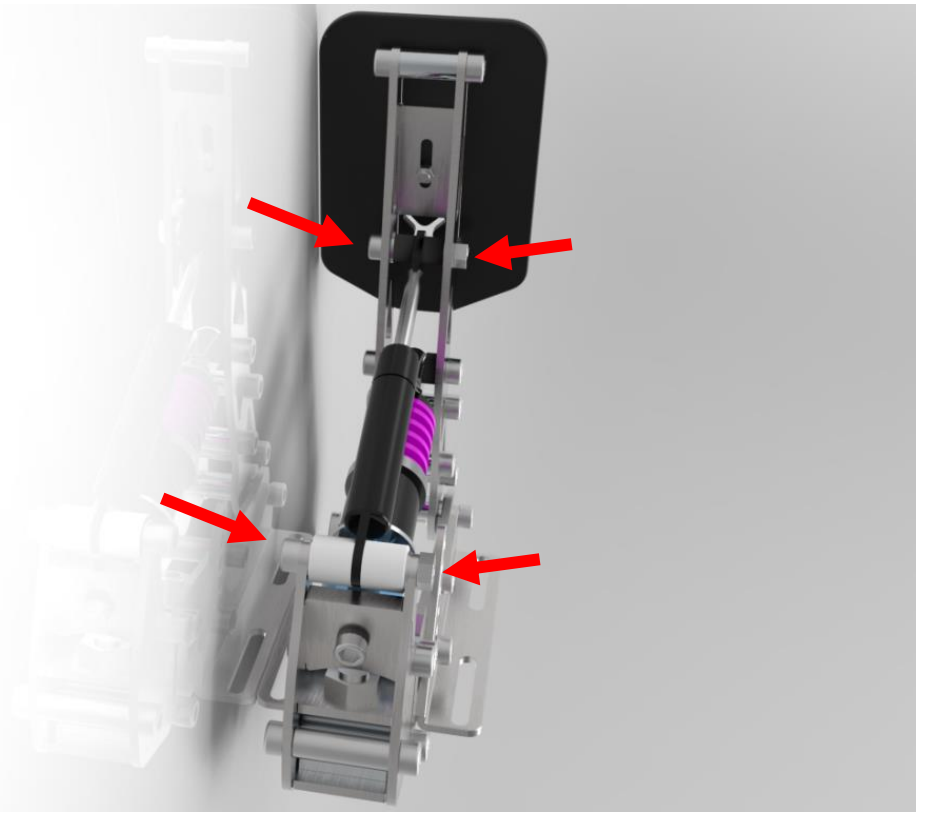

c) After placing all the parts, tighten the M6 bolts and nuts